

Nureva™ Span™ system

Mobile Span system



Interactive projector

Projector details	
Light source	Solid state: blue-laser diodes
Brightness	3300 ANSI lumens
Resolution	1920 x 1080
Aspect ratio	16:9
Throw ratio	0.25
Cart display (Width x height)	6' 2" x 3' 6" (1.88 x 1.07 m)
Brightness uniformity	80% (JBMA)
Contrast	1800:1 (native)/10,000:1 (APM)
Digital micromirror device (DMD)	TI 0.65" 1080p S600
Speaker	10W
Dimensions (Width x depth x height)	15.1" x 12.1" x 4.0" (38.3 x 31.0 x 10.2 cm)
Net weight	12.1 lb. (5.5 kg)
Shipping dimensions (Width x depth x height)	20.4" x 16.5" x 12.9" (51.8 x 42.0 x 32.8 cm)
Shipping gross weight	18.0 lb. (8.2 kg)

Projector input/output connections	
Input I/O	VGA In x 1
	Audio In 3.5 mm jack (blue) x 1
	Composite video x 1
	Composite audio In: RCA-left (white) x1/RCA-right (red) x 1
	HDMI x 2 (support for MHL 2.0 on HDMI 2)
	Microphone 3.5 mm jack (pink) x 1
Output I/O	RS-232C (DB9 female: 9600bps) x 1
	Mini USB x 1
Power	VGA Out/VGA 2
Multimedia control	Audio out 3.5 mm jack (green) x 1
	AC power IEC-C14, 110/220 V
	RJ45 X1 (Fast Ethernet 100Base-T)
	USB-A x 1

Certification and operating	
Power consumption	335W (typical); 225W (ECO)
Standby power	Idle without LAN wakeup: <0.5W
Electromagnetic compatibility	FCC, CE, CB
Safety	TUV, cUL, RCM, FDA
Rating	Universal switching 100 – 240V AC, 50 – 60Hz, 3.5A
Noise level	Full-mode: 36dBA (typical)/38 dBA (maximum) ECO mode: 32dBA (typical)/35 dBA (maximum)
System temperature/humidity	Operating: 5°C to 40°C/5% – 90% (noncondensing)
	Storage: -20°C to 60°C/5% – 95% (noncondensing)
Thermal protection	Shipping: -20°C to 60°C/5% – 95% (noncondensing)
Environment	Auto ECO: Ambient temperature exceeds 40°C Auto-shutdown: Ambient temperature exceeds 47°C
	RoHS, WEEE, REACH

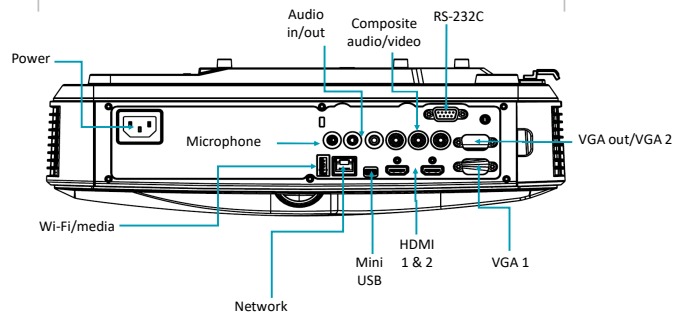
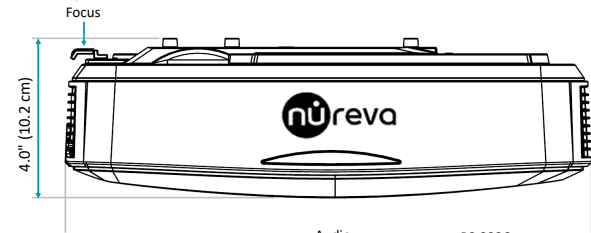
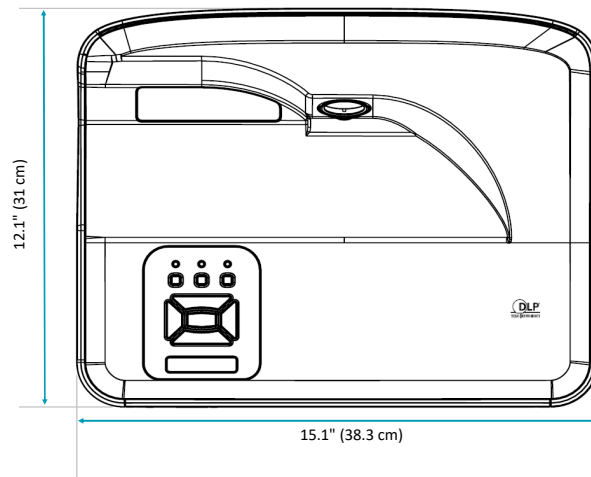

Mobile cart hardware

Cart details	
Material	Steel + aluminum + plastic
Handle	Aluminum, swivels to storage position
Wheels	2.9" (7.4 cm) diameter
Cart dimensions (Width x depth x height)	16.4" x 20.9" x 27.6" (41.6 x 53.1 x 70.1 cm)
Cart handle dimensions (Width x diameter x height)	10.5" x 1.25" x 16" (26.7 x 3.2 x 40.6 cm)
PC shelf dimensions (Width x depth x height)	16.0" x 14.0" x 7.8" (40.6 x 35.5 x 19.8 cm)
Net weight	35.7 lb. (16.2 kg)
Shipping dimensions (Width x depth x height)	22.4" x 26.0" x 31.9" (57.0 x 66.0 x 81.0 cm)
Shipping gross weight	45 lb. (20.4 kg)

Input/output connections	
Input I/O	USB x 1
Power	AC power IEC-C14, 110/220 V
Cabling	USB cable, USB-B Mini to USB-A, 3' (0.9 m), black
	HDMI cable, HDMI-A to HDMI-A, 3' (0.9 m)
	PC power cord, C13 to C14, 1' (0.3 m), Universal to C14 adaptor (international only)
	PC power cord, C13 to Nema 5-15R, 1' (0.3 m)
	Cart power cord, IEC60320-C13, 14.8' (4.5 m), white
	Projector power cord, C13 to C14, 1' (0.3 m)
	USB 3.0 panel mount extension cable, type A, 3' (0.9 m)

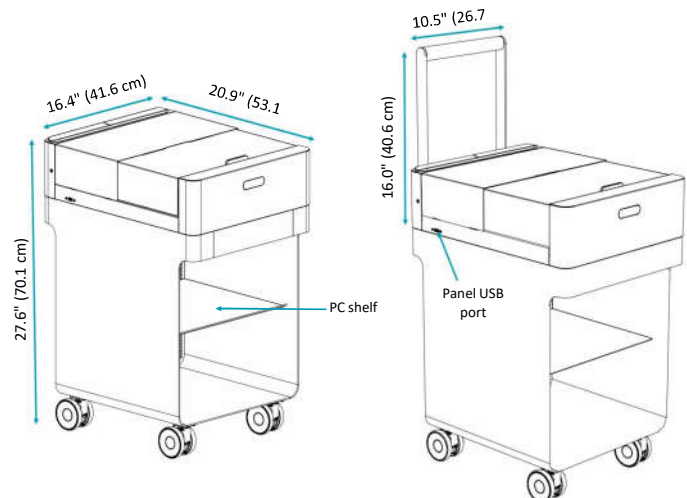

Nureva™ Span™ system

Mobile Span system



Active stylus

General specifications	
Image size support (Width x height)	6' 2" x 3' 6" (1.88 x 1.07 m)
Pen tip	Replaceable polyethylene nib
Batteries	2 x AAA (included)
Dimension (Length x diameter)	5.4" x 0.4" (13.8 x 1.1 cm)
Net weight	2.1 oz. (60.0 g)
Shipping dimensions and gross weight	N/A – included with projector

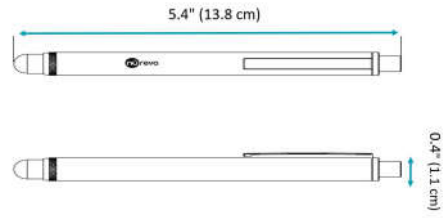

Display setup

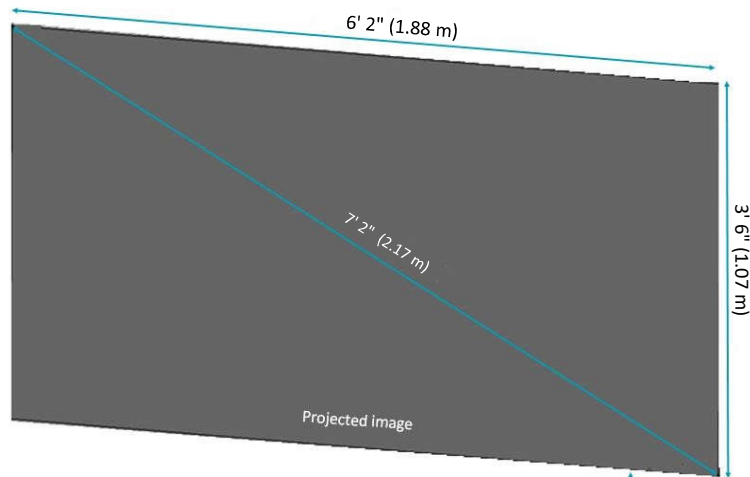

NOTE: PC is not included.
For the recommended PC requirements,
see Nureva-span.uservice.com

